

Issue:	Drawn By:	Checked By:	CRF No.:	Date:	Description:
a	FT	KB	3638	09/01/26	First Issue
b					
c					
d					

SV4KE

KammEdge.

Instructions

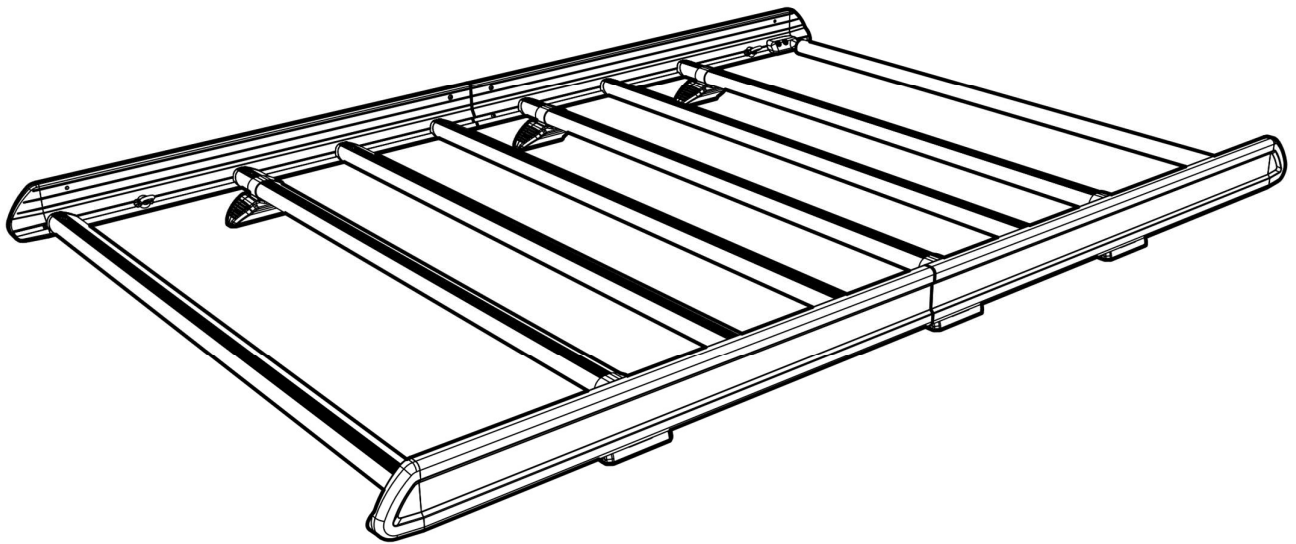

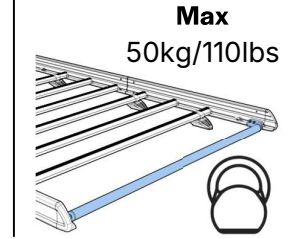
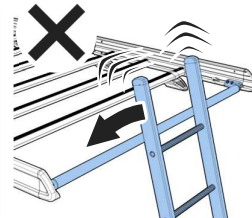

KammEdge

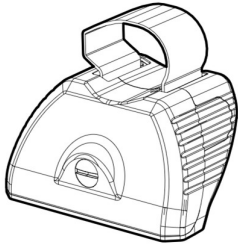

SA397U x 4

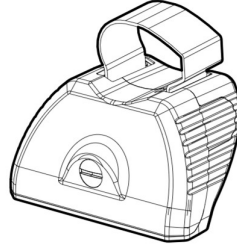

SA398U x 4

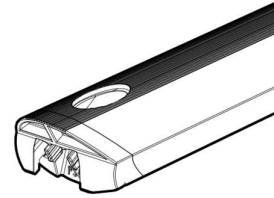

SA430/SA468 x 8

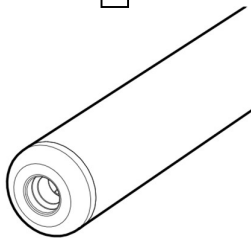

SA438 x 1

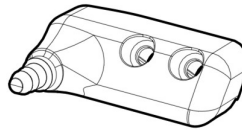

PS519 x 1

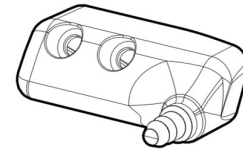

PS520 x 1

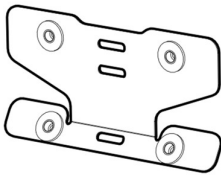

SA610 x 2



PS635 x 2

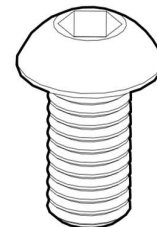

**FS323
(M6 x 16) x 8**

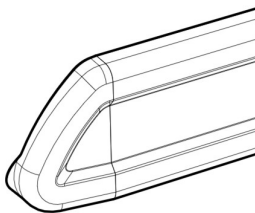

LSF (L) x 2

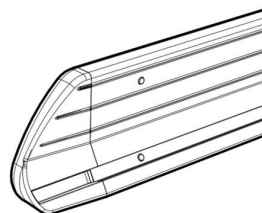

LSF (R) x 2



C04 x 8
optional upgrade

Fitting Kit

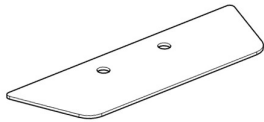

PS619 x 2

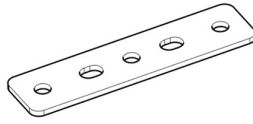

PS023 x 8

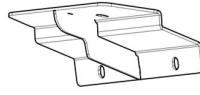

SW564 x 2

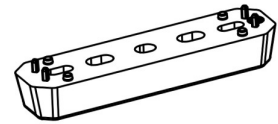

PS183 x 8



FN006 (M8)
x 4

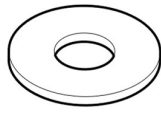

FW002
(M8x21) x 18

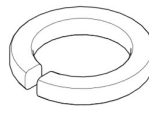

FW020 (M8)
x 14

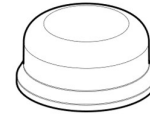

PS414 (M8) x 4

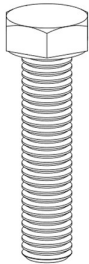

FS081
(M8 x 50)
x 4

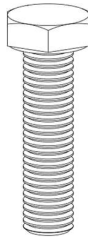

FS066
(M8 x 40)
x 6

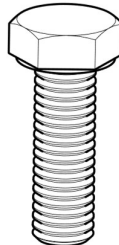

FS015
(M8 x 25)
x 4

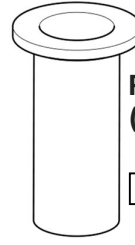

FN079
(M8) x 4



FS059
(M8 x 25) x 16

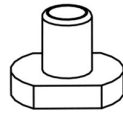

FN085 x 16



FT01 x 1



FT05 x 1



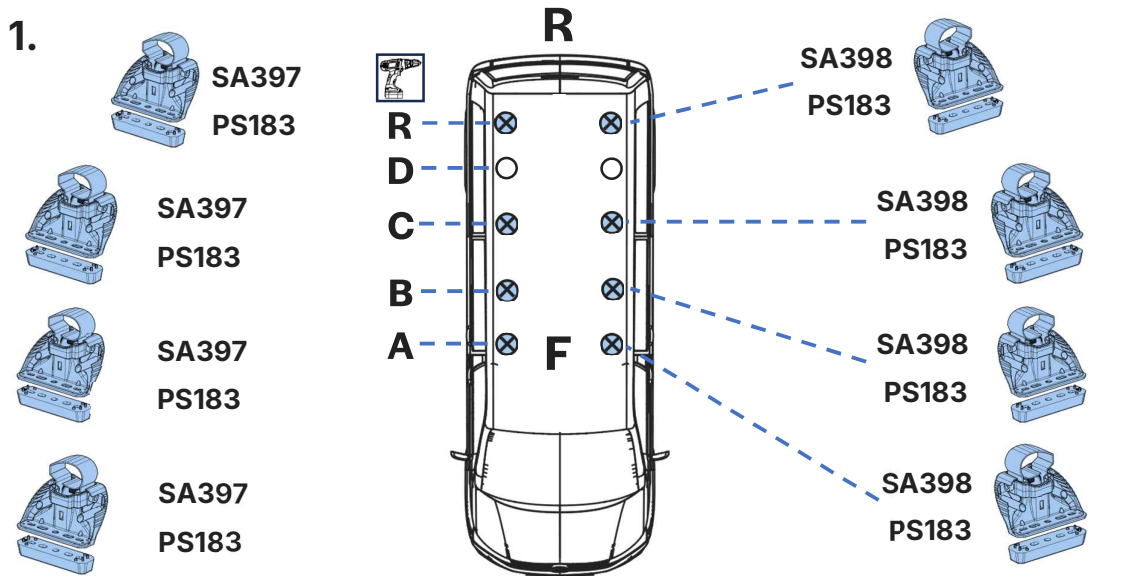

2.A/B/C

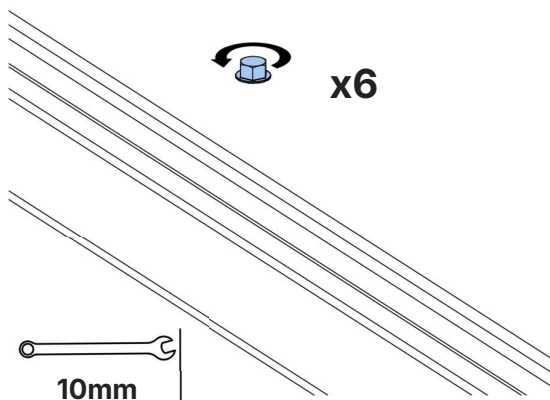

3.

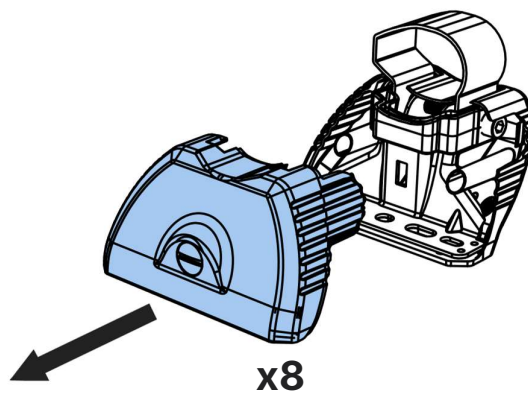

4.

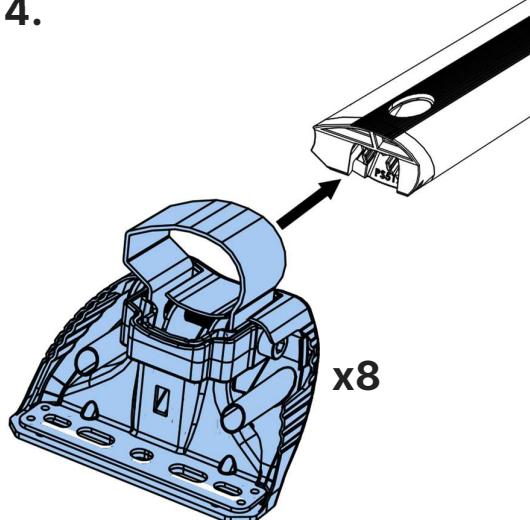

5.

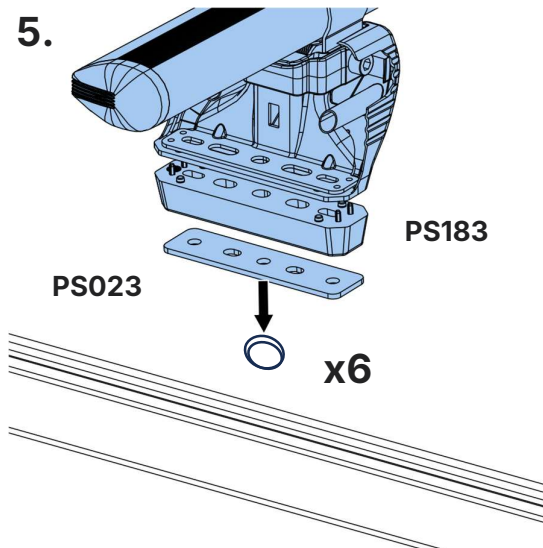

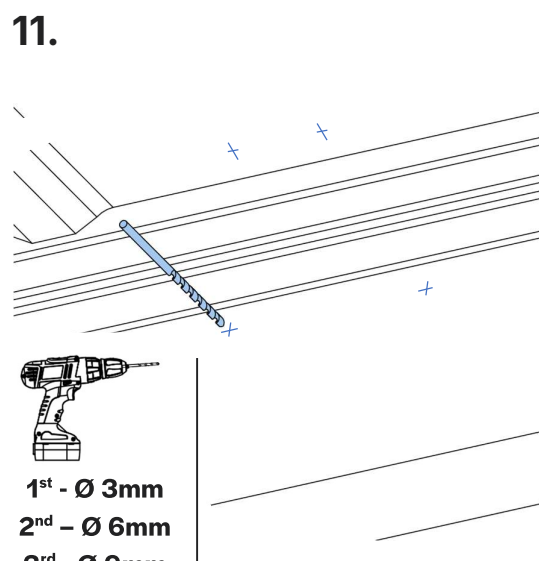
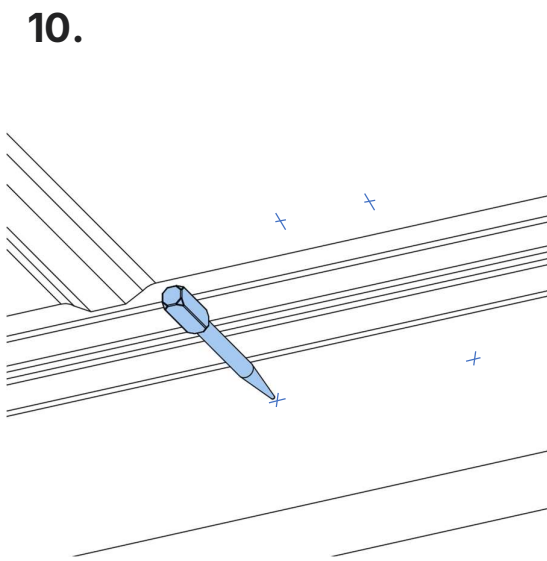
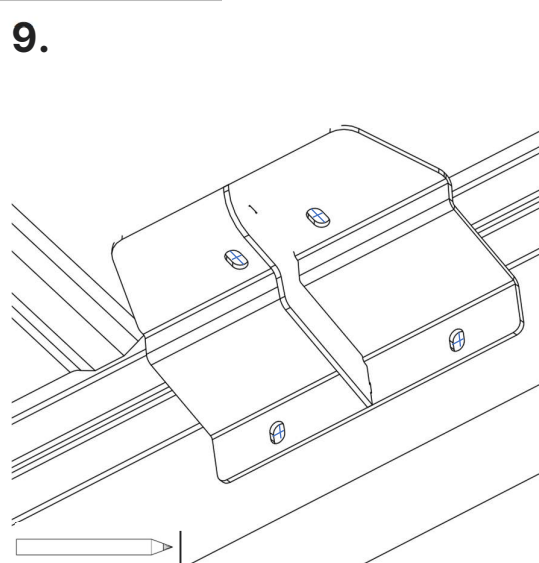
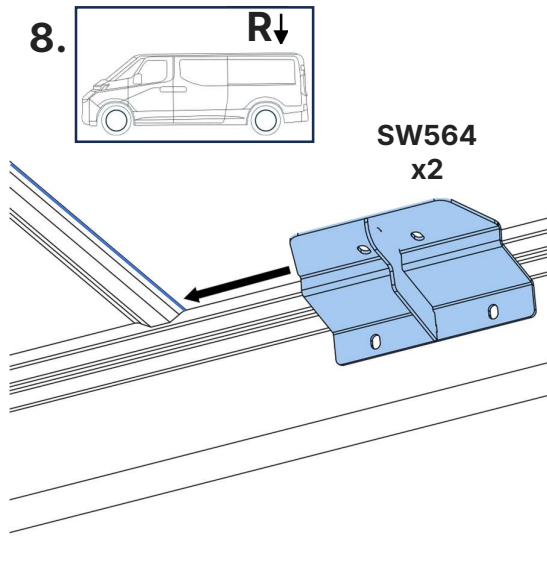
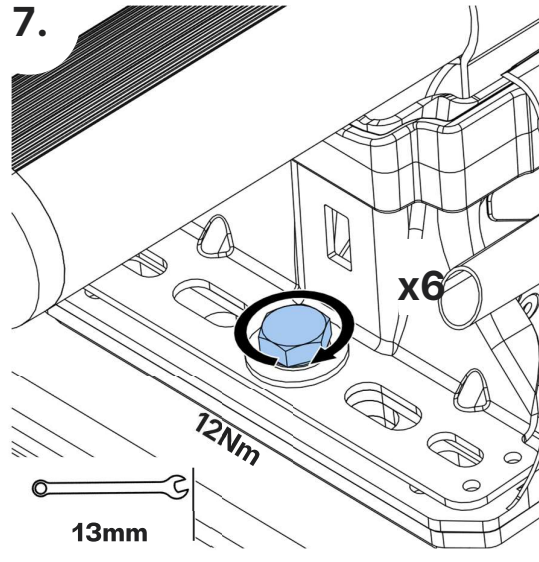
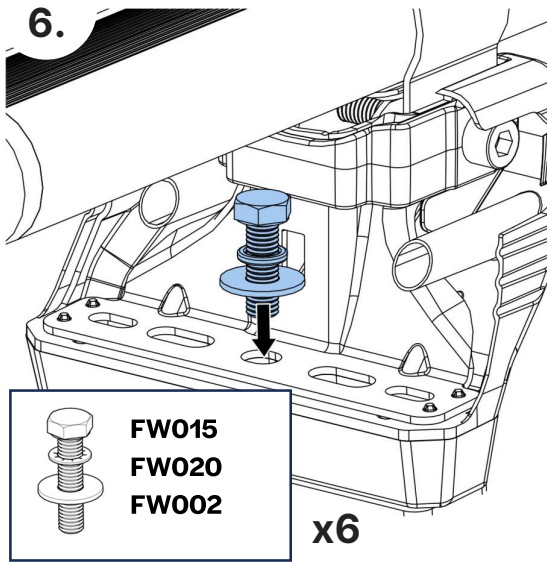

12.

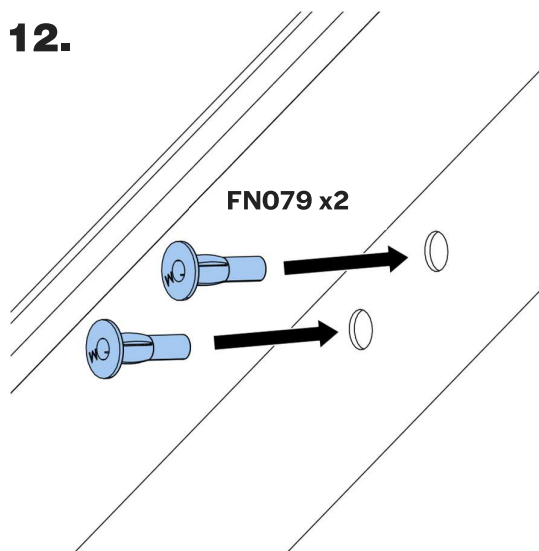

13.

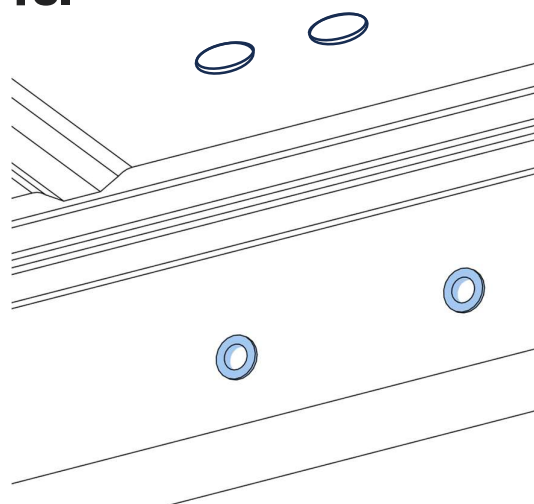

14a.

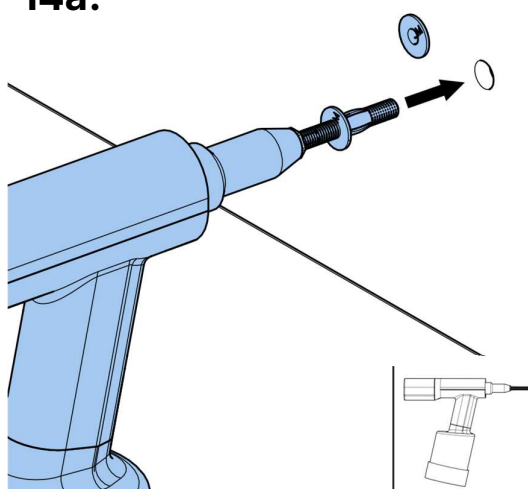

	Option 1: Use Rivet Gun & M8 XL Mandrel.
	Option 1: Benutzen Sie eine Nietpistole & einen M8 XL Zugdorn.
	Option 1: Utiliser un pistolet à riveter et un mandrin M8 XL.
	Opzione 1: utilizzare una pistola per rivetti e un mandrino M8 XL.
	Opción 1: Use la remachadora y el cabezal M8 XL.
	Opcja 1: należy użyć nitownicy z trzpieniem M8 XL.
	Optie 1: Gebruik Klanknagelpistool & M8 XL Opspandoorn.
	1. opció Használjon szegecselő pisztolyt és M8 XL tűskét.
	Alternativ 1: Använd en nitpistol och en M8 XL borraradapter.
	Varianta 1: Použijte nýtovací kladivo a trn M8 XL.
	Vaihtoehto 1: Käytä niittivasaraa ja M8 XL -tuurua.
	Alternativ 1: Bruk naglepistol og M8 XL-mandreng.
	Možnosť 1: Použite nitovací pištoľ a trň M8 XL.

14b.

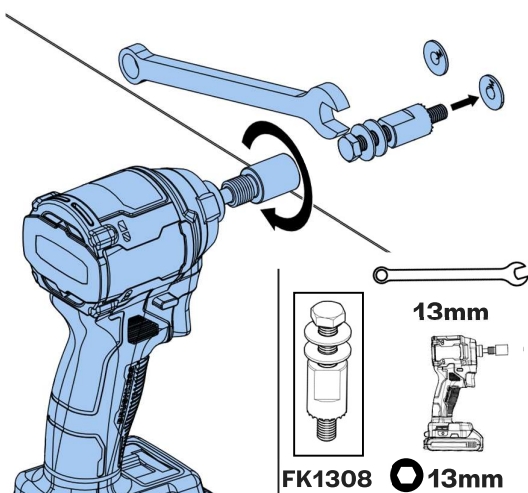

	Option 2: Use Impact Driver.
	Option 2: Benutzen Sie einen Schlagschrauber.
	Option 2: Utiliser une clé à choc.
	Opzione 2: utilizzare l'avvitatore a percussione.
	Opción 2: Use el atornillador de impacto.
	Opcja 2: należy użyć wkrętarki udarowej.
	Optie 2: Gebruik Slagschroevendraaier.
	2. opció Használjon ütvefúrót.
	Alternativ 2: Använd en slagbormmaskin.
	Varianta 2: Použijte příklepový utahovák.
	Vaihtoehto 2: Käytä iskuväännintä.
	Alternativ 2: Bruk slagskrutrekker.
	Možnosť 2: Použite elektrický utahovák.

14c.

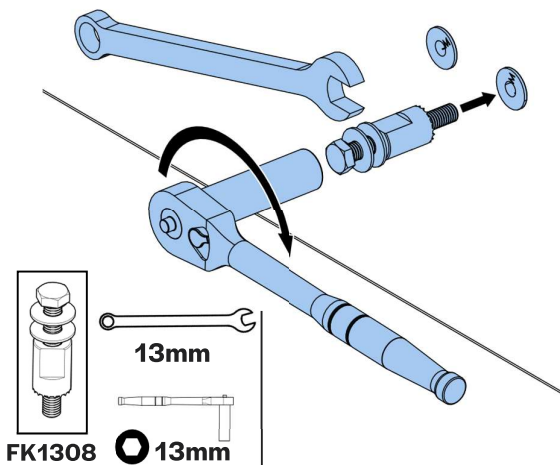

	Option 2: Use Impact Driver.
	Option 2: Benutzen Sie einen Schlagschrauber.
	Option 2 : Utiliser une clé à choc.
	Opzione 2: utilizzare l'avvitatore a percussione.
	Opción 2: Use el atornillador de impacto.
	Opcja 2: należy użyć wkrętarki udarowej.
	Optie 2: Gebruik Slagschroevendraaier.
	2. opció Használgjon ütvefúrót.
	Alternativ 2: Använd en slagbormmaskin.
	Varianta 2: Použijte příklepový utahovák.
	Vaihtoehto 2: Käytä iskuväännintä.
	Alternativ 2: Bruk slagskrutrekker.
	Možnosť 2: Použite elektrický ťahovák.

15.

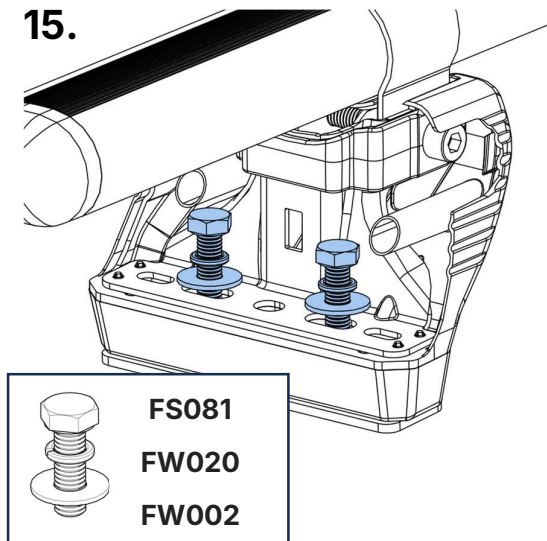

16.

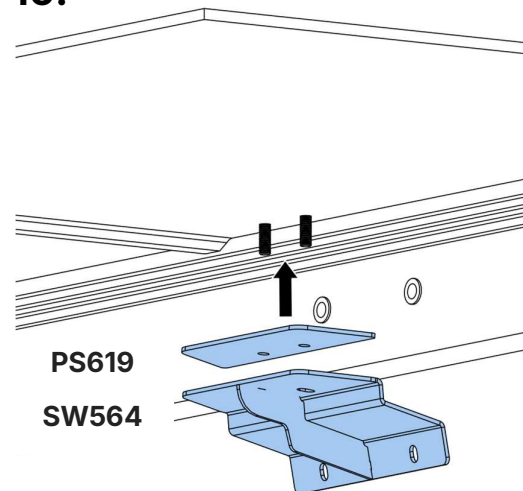

17.

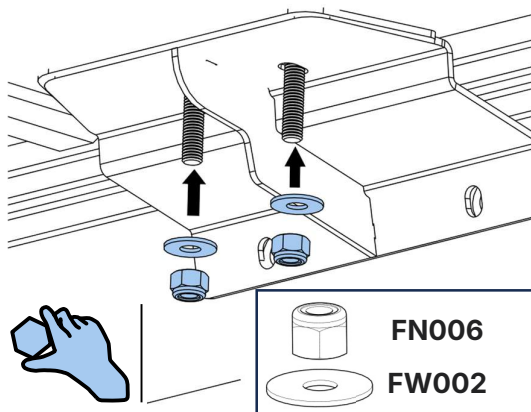

18.

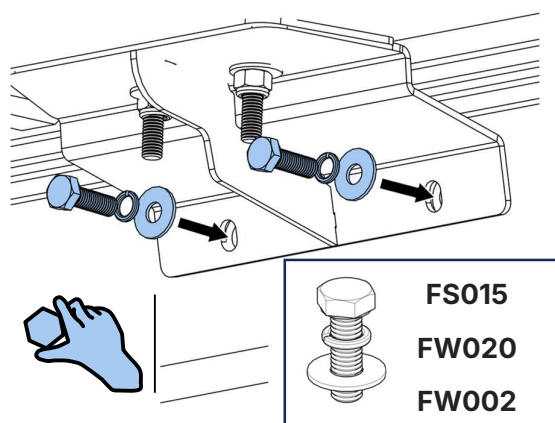

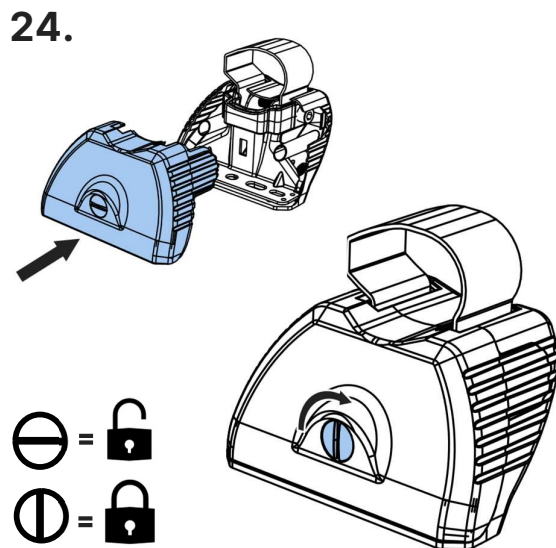
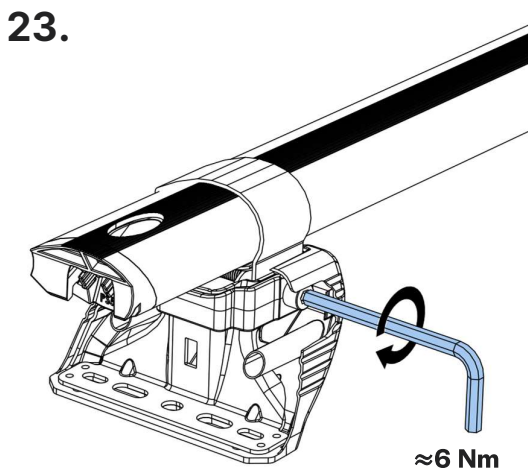
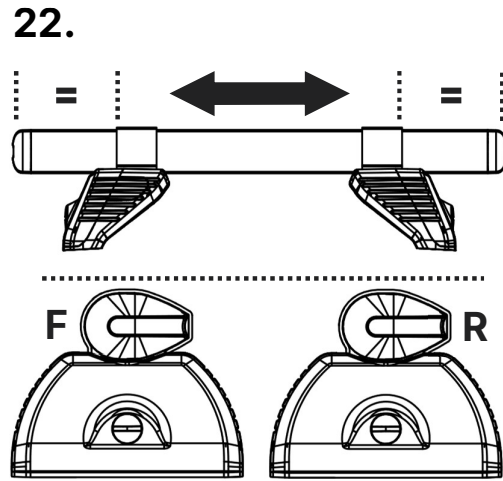
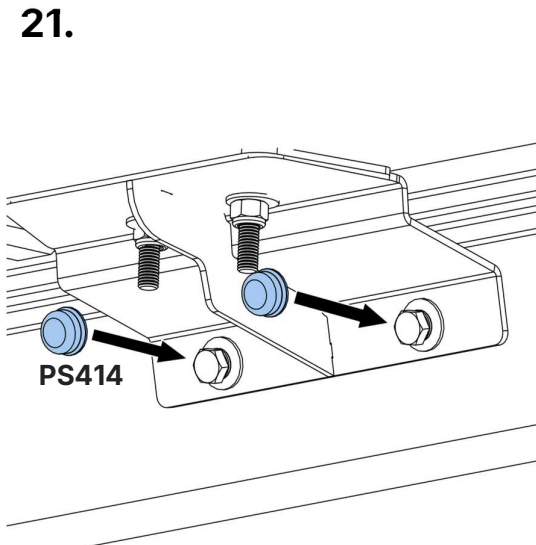
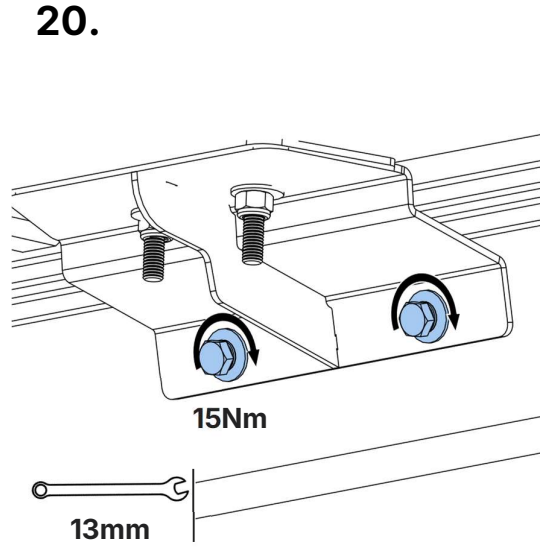
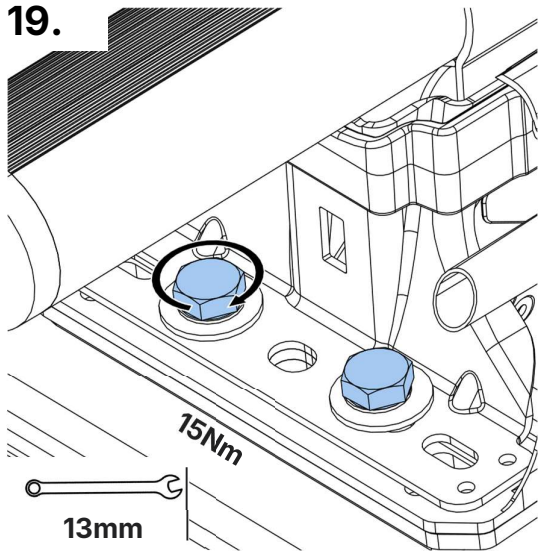

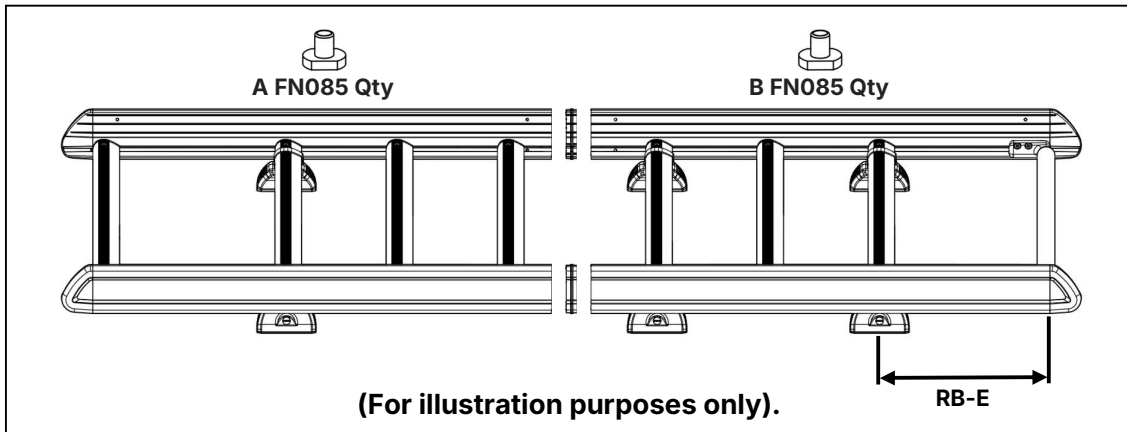
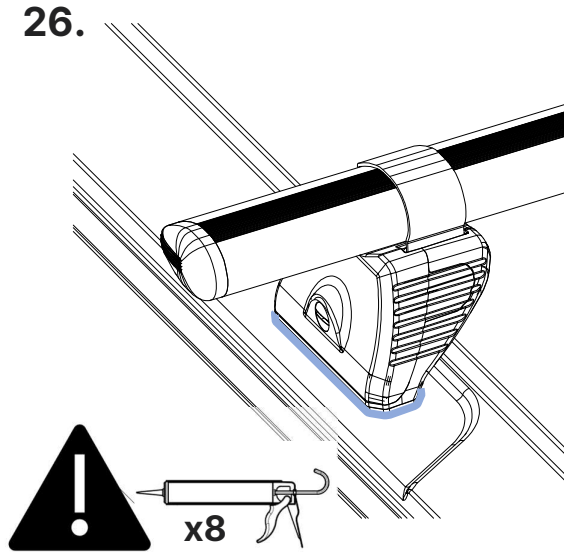
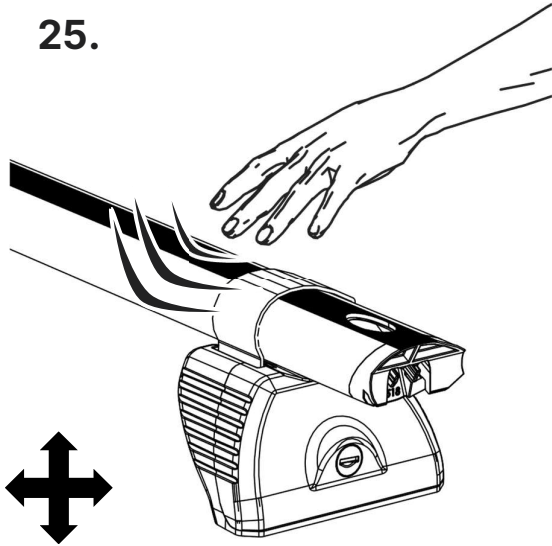

L800/LB800- PV5 2026-, L2-H1 (Twin)

Max Load = 150kg/330lbs



L800/LB800 = 28kg/62lbs

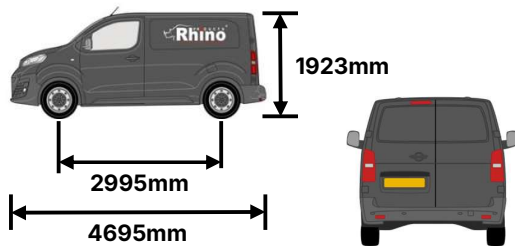

A FN085 Qty	B FN085 Qty	Rear Bar – End (mm)
3	5	600

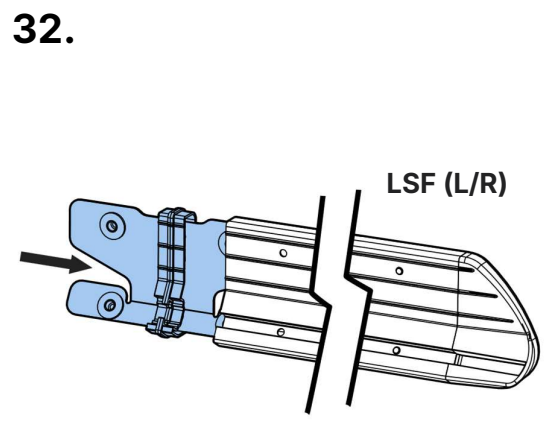
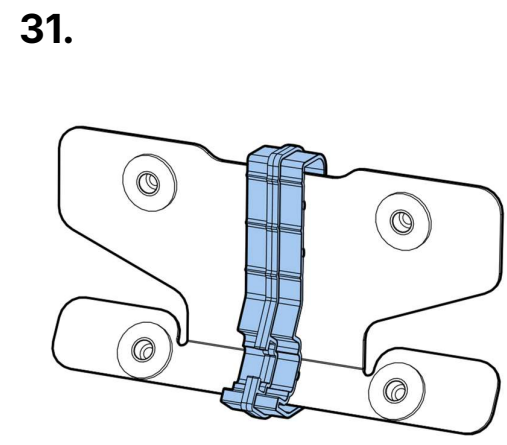
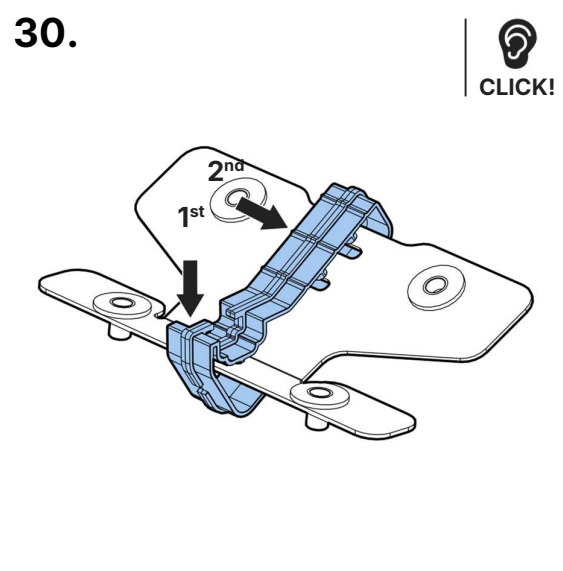
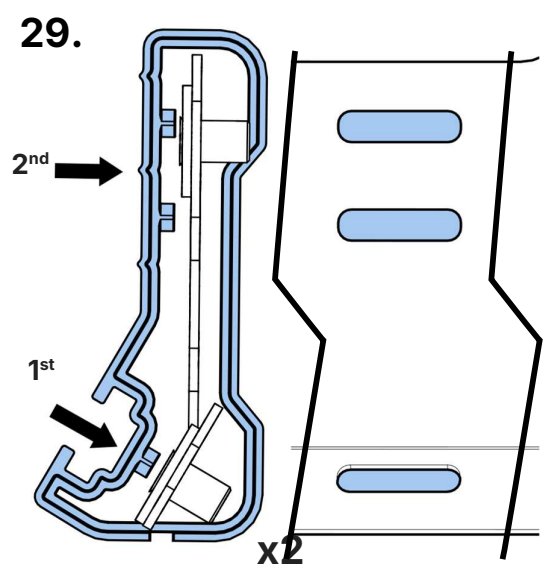
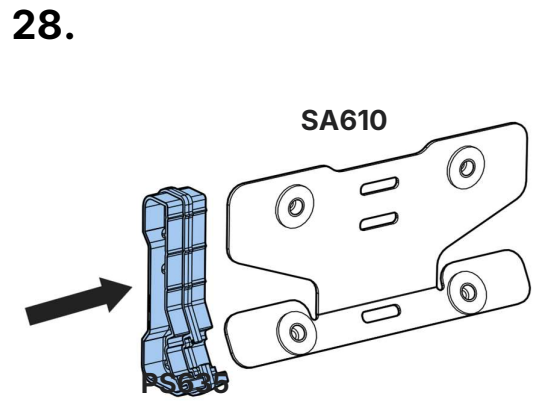
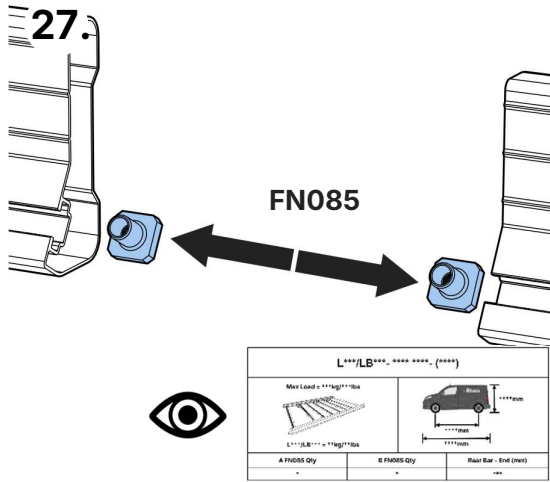

33.

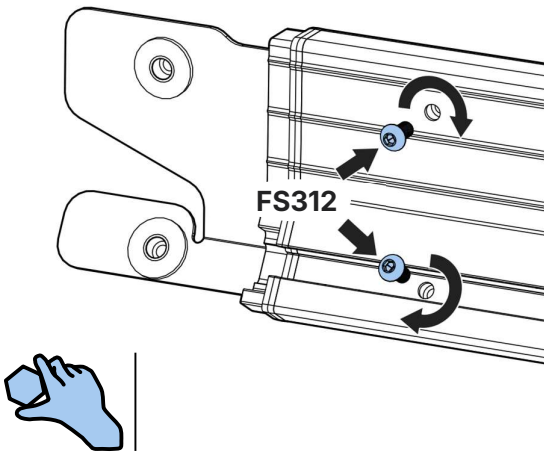

34.

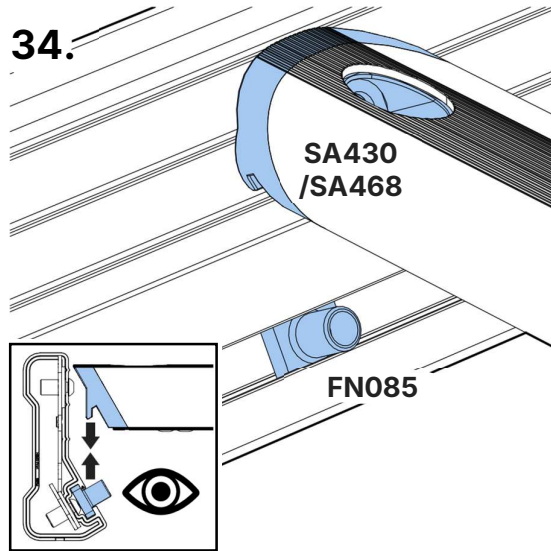

35.

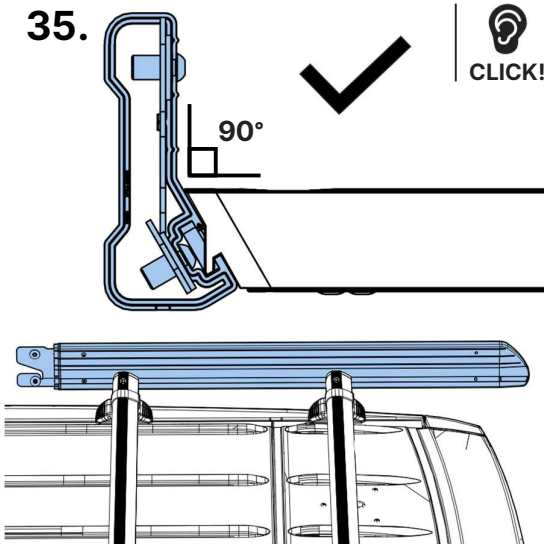

36.

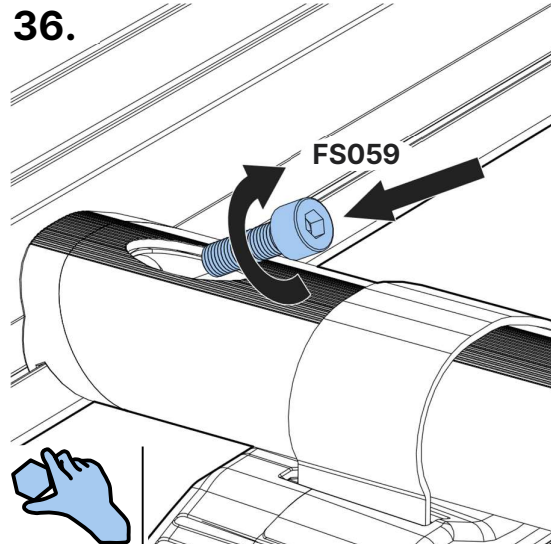

37.

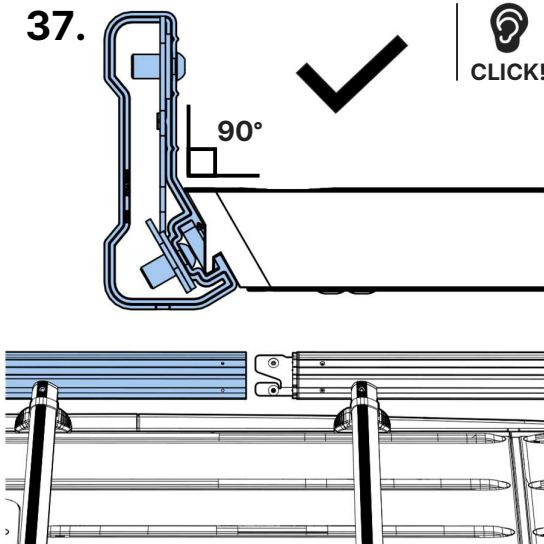

38.

