

<b>ISSUE:</b>	<b>DRAWN BY:</b>	<b>CHECKED BY:</b>	<b>CRF No:</b>	<b>DATE:</b>	<b>DESCRIPTION:</b>
a	FT	KB	3643	04/02/26	First Release
b					
c					
d					
e					
f					
g					
h					
i					
j					
k					
l					
m					

# YA4KR KammRack Instructions

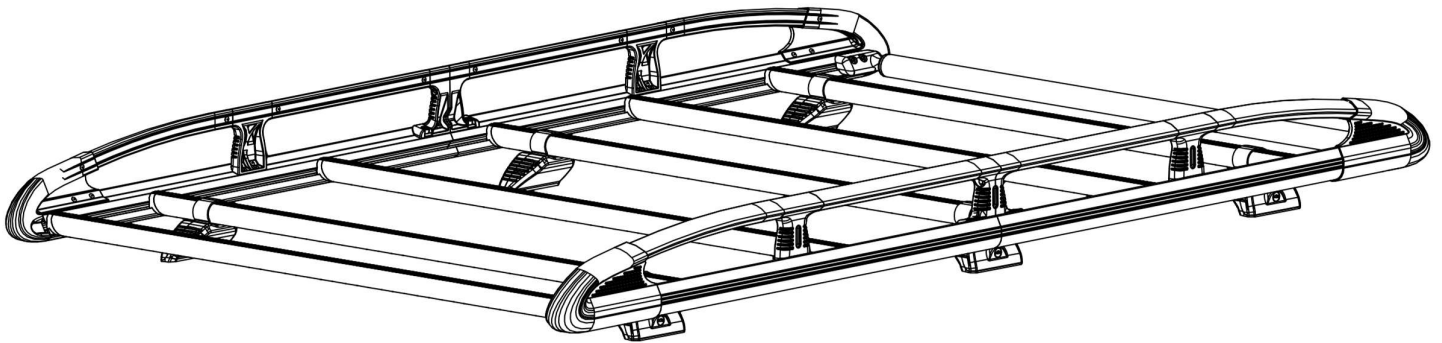

**CITY CRASH** (✓)

According to ISO/ PAS 11154:2006

YA4KR:

Kia PV5 2026-

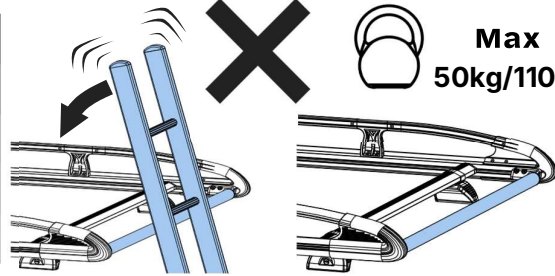
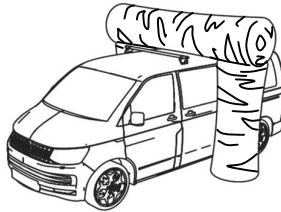
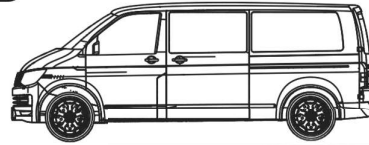

## KammRack

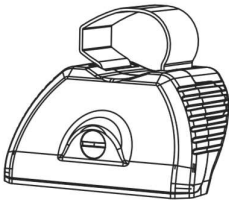

SA397U x 4

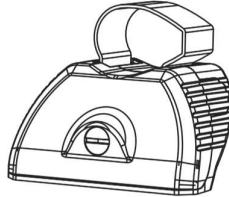

SA398U x 4

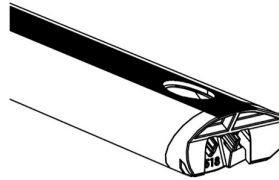

SA430 x7

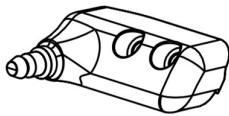

PS519 x 1

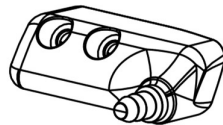

PS520 x 1

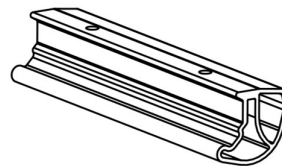

EXT15-02

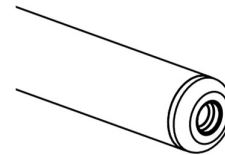

SA437 x 1

LHS x 2

RHS x 2

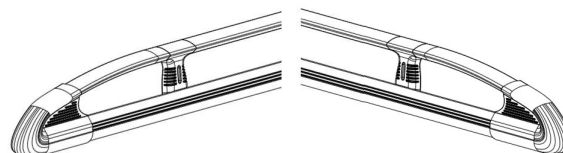

ASF x 1

# Fitting Kit

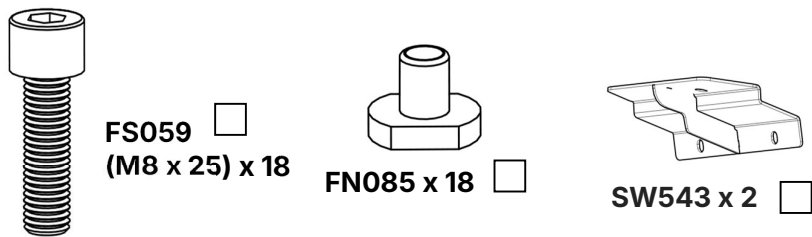
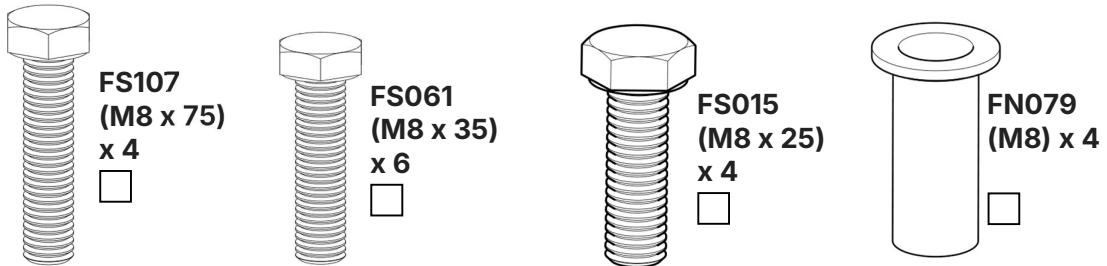
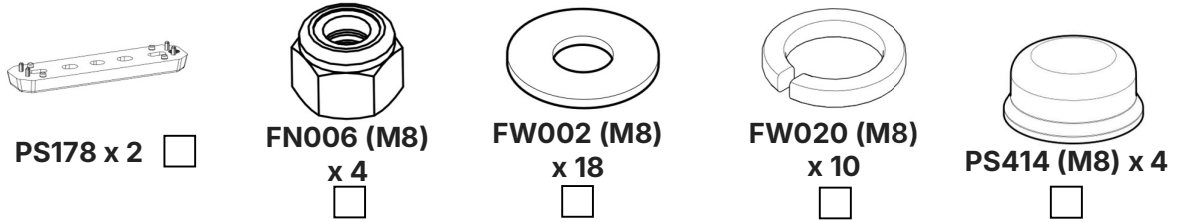
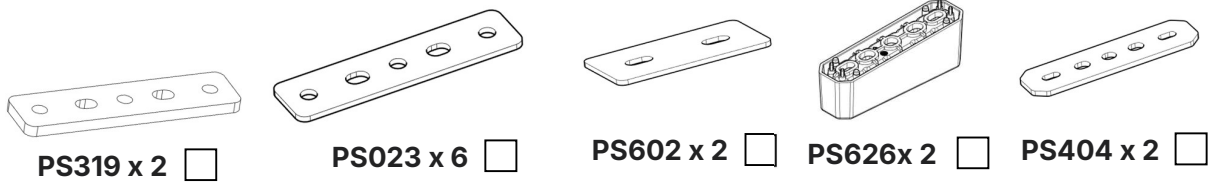

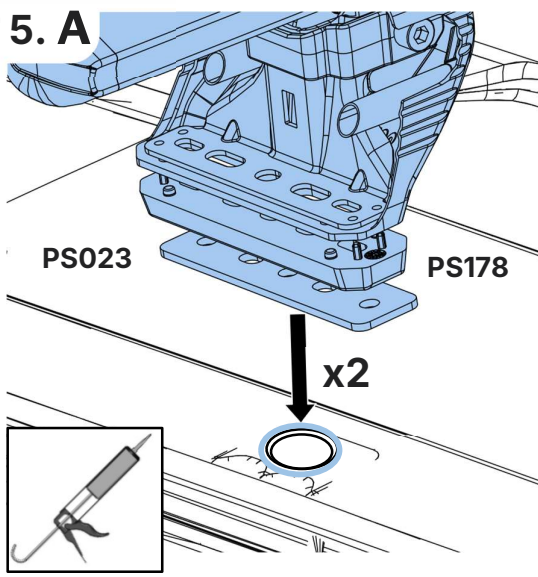
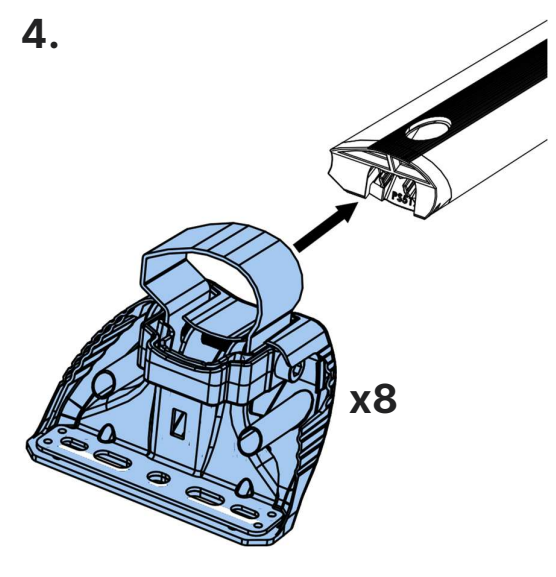
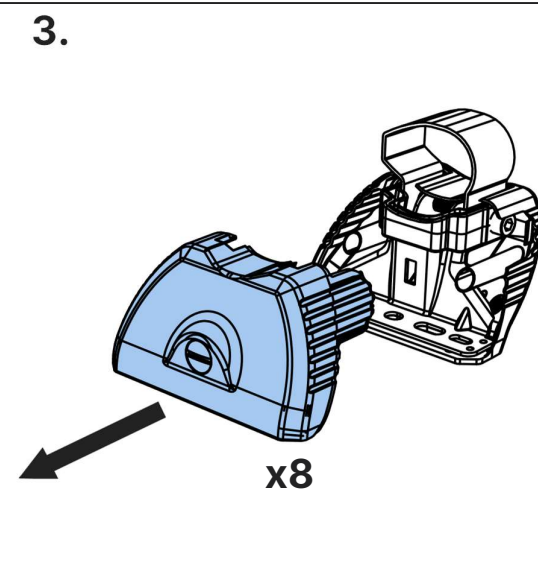
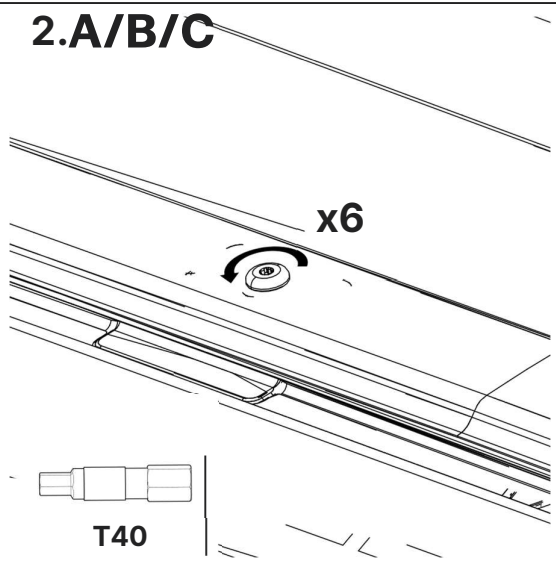
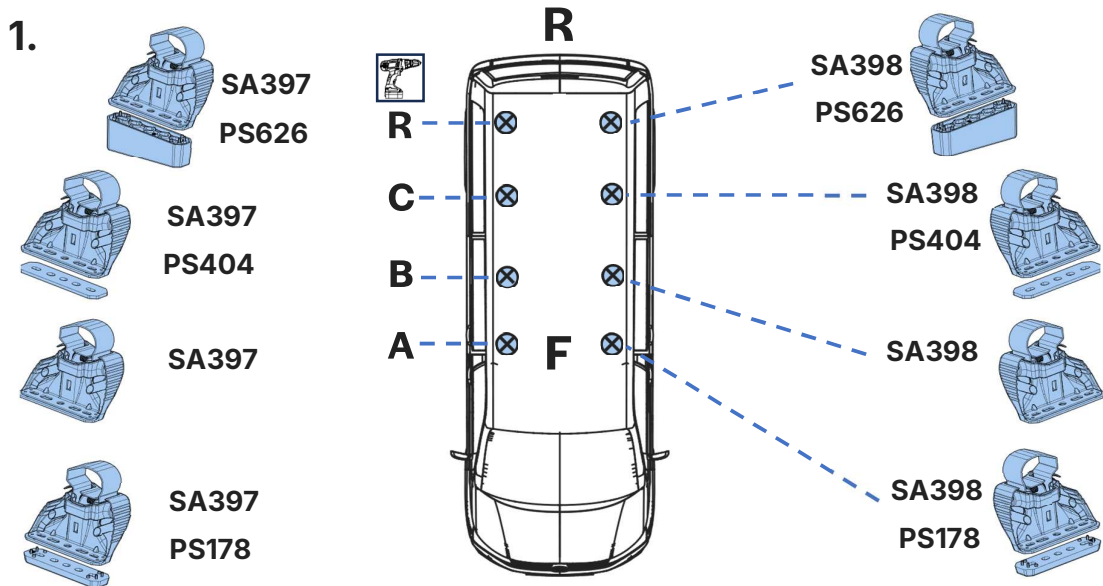

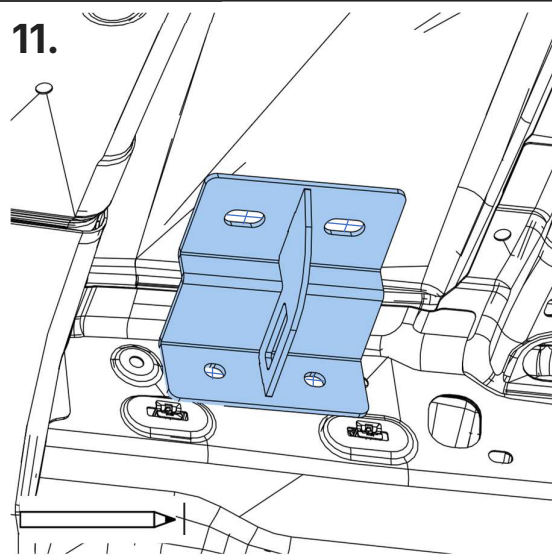
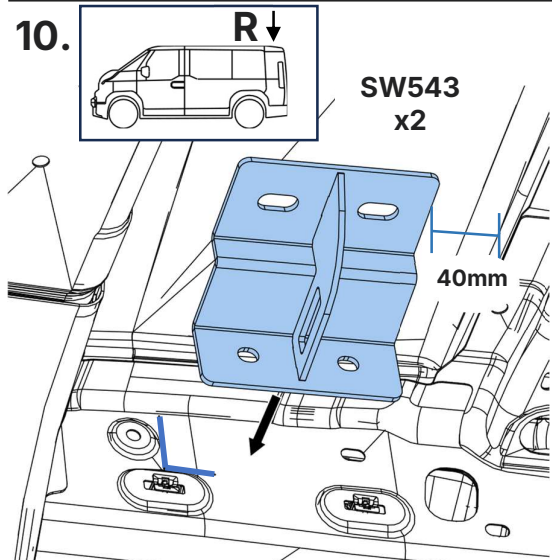
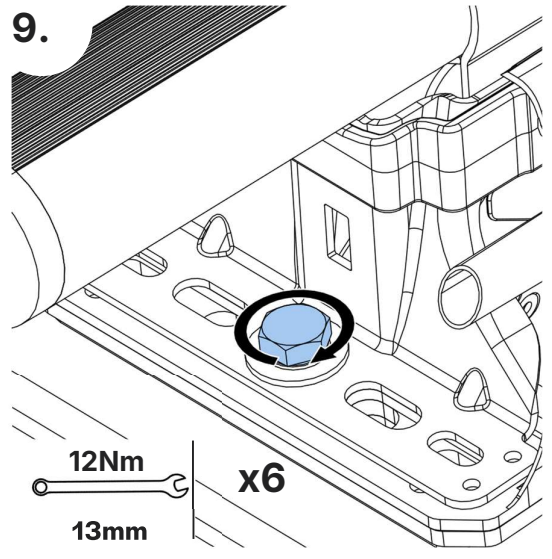
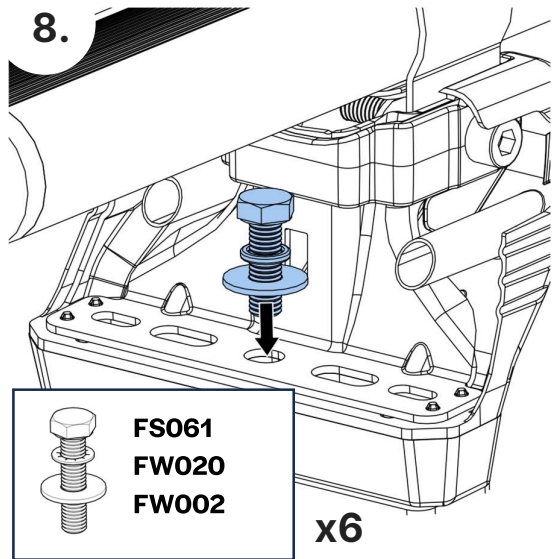
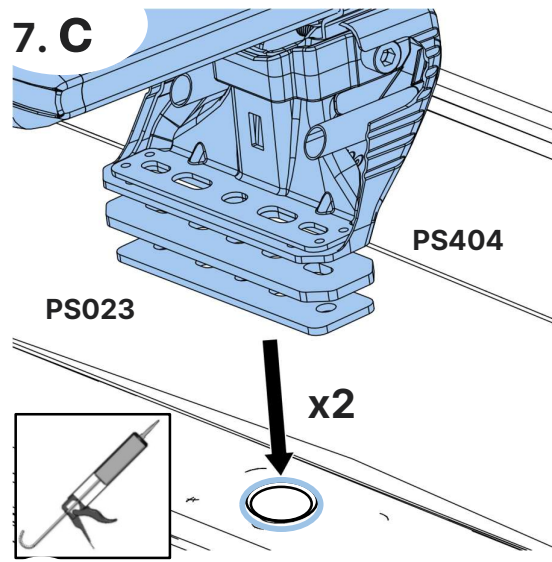
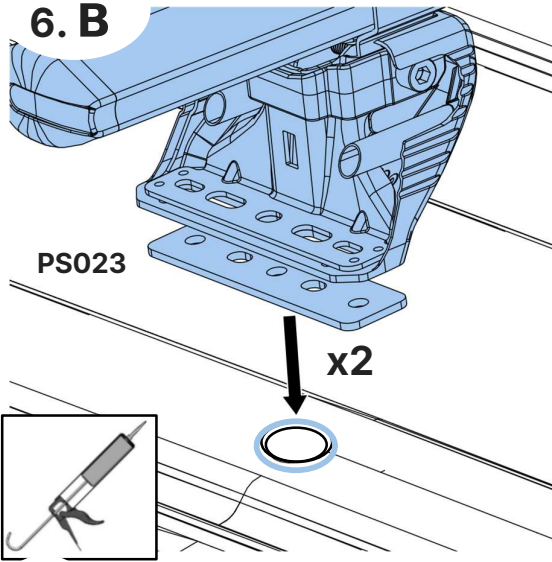

12.

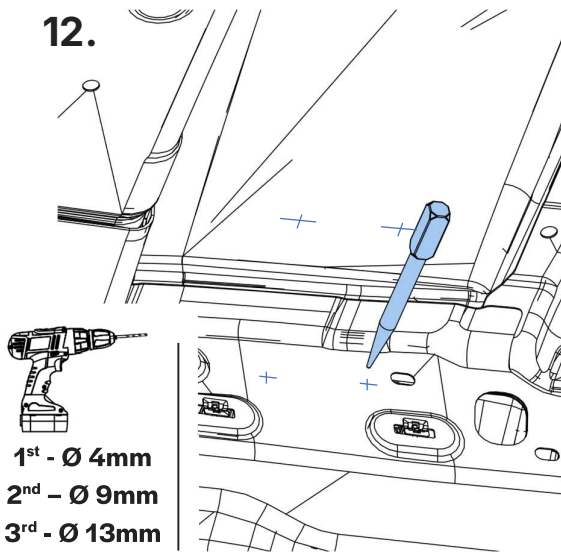

1<sup>st</sup> - Ø 4mm  
2<sup>nd</sup> - Ø 9mm  
3<sup>rd</sup> - Ø 13mm

13.

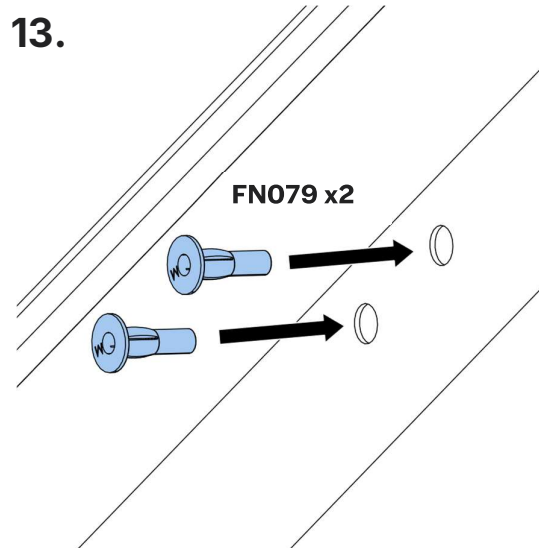

14a.

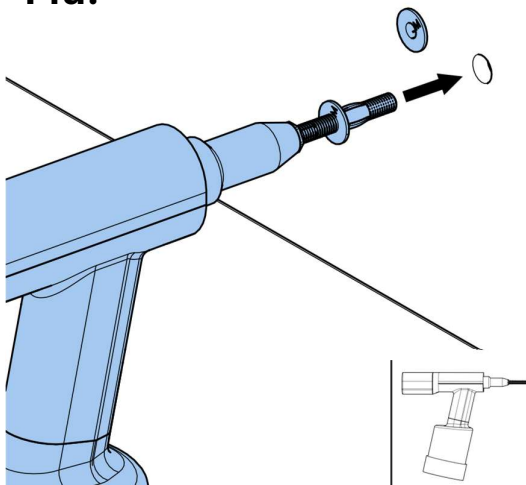

	<b>Option 1:</b> Use Rivet Gun & M8 XL Mandrel.
	<b>Option 1:</b> Benutzen Sie eine Nietpistole & einen M8 XL Zugdorn.
	<b>Option 1:</b> Utiliser un pistolet à riveter et un mandrin M8 XL.
	<b>Opzione 1:</b> utilizzare una pistola per rivetti e un mandrino M8 XL.
	<b>Opción 1:</b> Use la remachadora y el cabezal M8 XL.
	<b>Opcja 1:</b> należy użyć nitownicy z trzpieniem M8 XL.
	<b>Optie 1:</b> Gebruik Klanknagelpistool & M8 XL Opspandoorn.
	<b>1. opció</b> Használjon szegecselő pisztolyt és M8 XL tűskét.
	<b>Alternativ 1:</b> Använd en nitpistol och en M8 XL borraradapter.
	<b>Varianta 1:</b> Použite nýtovací kladivo a trň M8 XL.
	<b>Vaihtoehto 1:</b> Käytä niittivasaraa ja M8 XL -tuurua.
	<b>Alternativ 1:</b> Bruk naglepistol og M8 XL-mandreng.
	<b>Možnost 1:</b> Použite nitovací pištoľ a trň M8 XL.

14b.

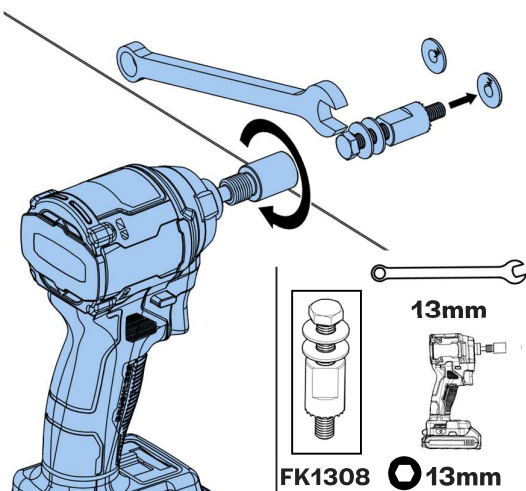

	<b>Option 2:</b> Use Impact Driver.
	<b>Option 2:</b> Benutzen Sie einen Schlagschrauber.
	<b>Option 2:</b> Utiliser une clé à choc.
	<b>Opzione 2:</b> utilizzare l'avvitatore a percussione.
	<b>Opción 2:</b> Use el atornillador de impacto.
	<b>Opcja 2:</b> należy użyć wkrętarki udarowej.
	<b>Optie 2:</b> Gebruik Slagschroevendraaier.
	<b>2. opció</b> Használjon ütvefúrót.
	<b>Alternativ 2:</b> Använd en slagbormmaskin.
	<b>Varianta 2:</b> Použite príklepový uťahovák.
	<b>Vaihtoehto 2:</b> Käytä iskuväännintä.
	<b>Alternativ 2:</b> Bruk slagskrutrekker.
	<b>Možnost 2:</b> Použite elektrický uťahovák.

14c.

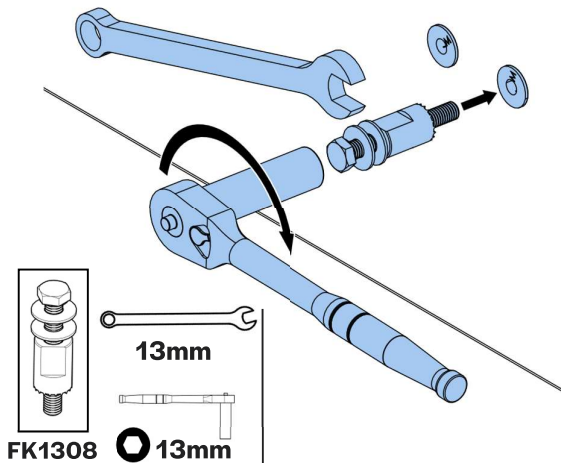

	<b>Option 2:</b> Use Impact Driver.
	<b>Option 2:</b> Benutzen Sie einen Schlagschrauber.
	<b>Option 2 :</b> Utiliser une clé à choc.
	<b>Opzione 2:</b> utilizzare l'avvitatore a percussione.
	<b>Opción 2:</b> Use el atornillador de impacto.
	<b>Opcja 2:</b> należy użyć wkrętarci udarowej.
	<b>Optie 2:</b> Gebruik Slagschroevendraaier.
	<b>2. opció</b> Használgjon ütvefűrót.
	<b>Alternativ 2:</b> Använd en slagbormaskin.
	<b>Varianta 2:</b> Použite príklepový uťahovák.
	<b>Vaihtoehto 2:</b> Käytä iskuväännintä.
	<b>Alternativ 2:</b> Bruk slagskrutrekker.
	<b>Možnosť 2:</b> Použite elektrický uťahovák.

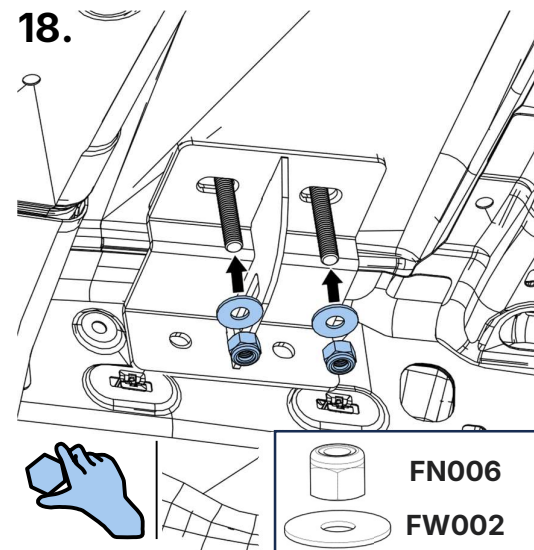
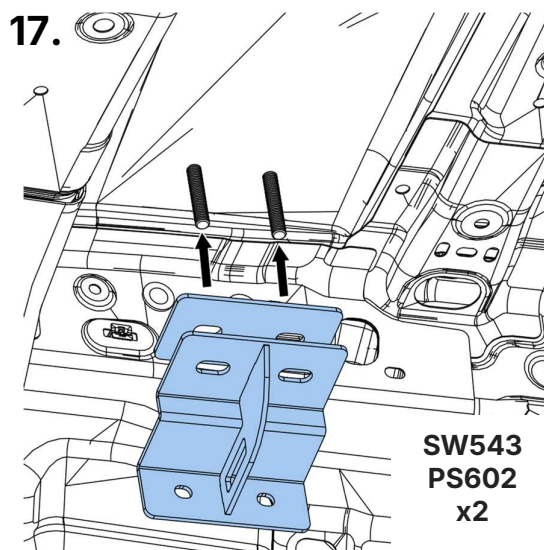
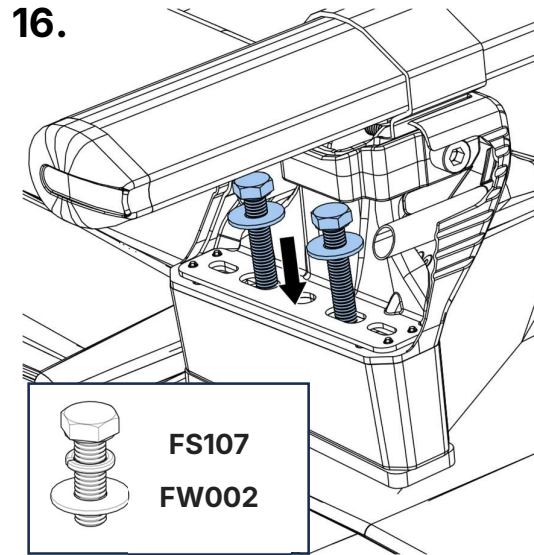
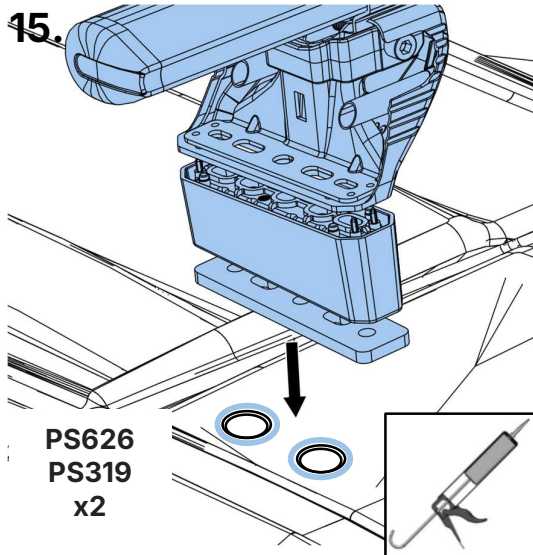

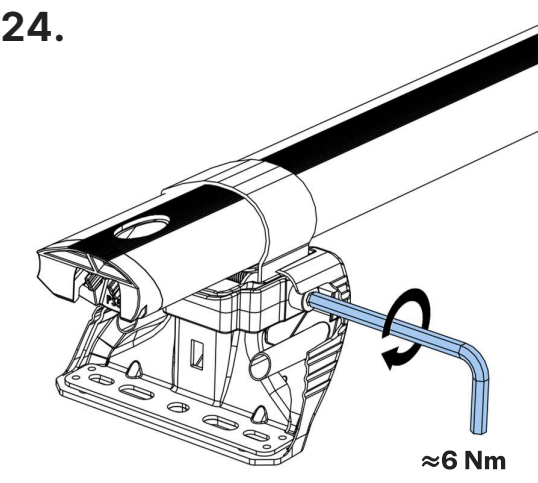
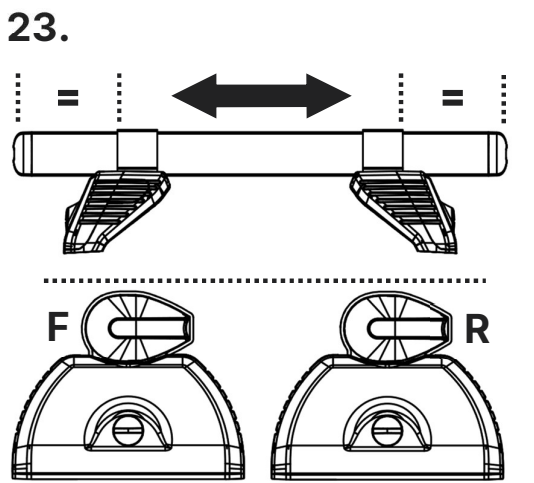
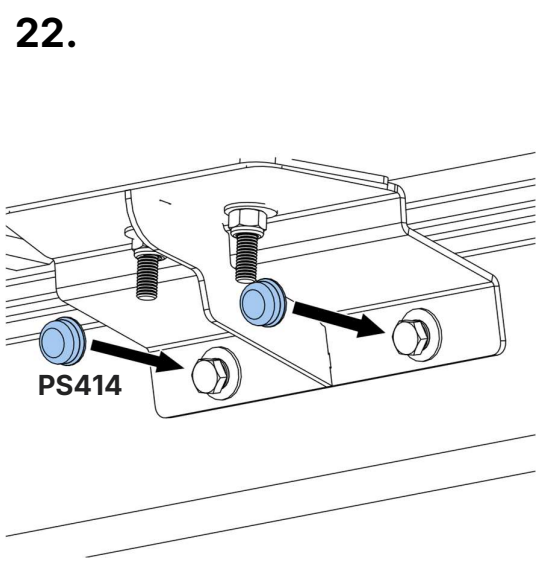
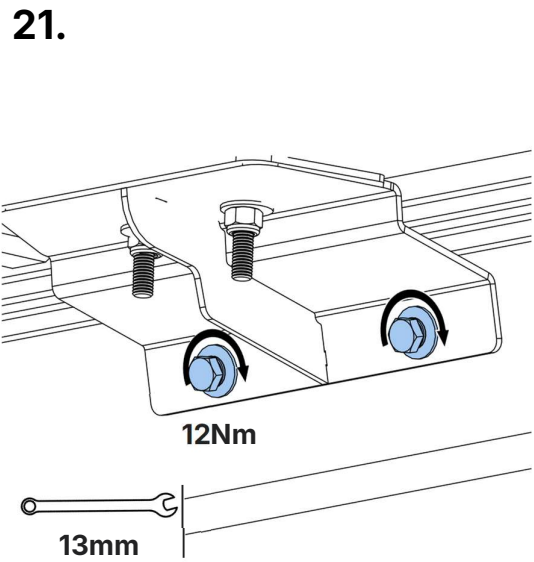
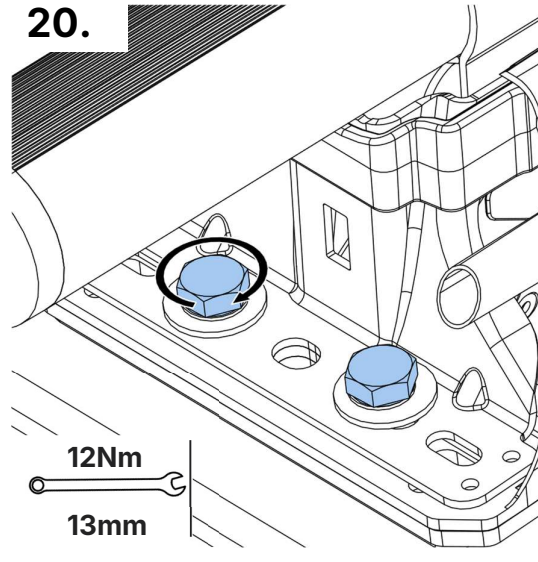
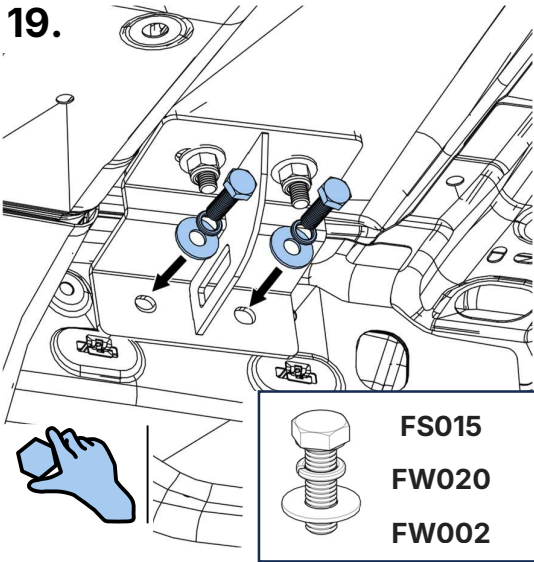

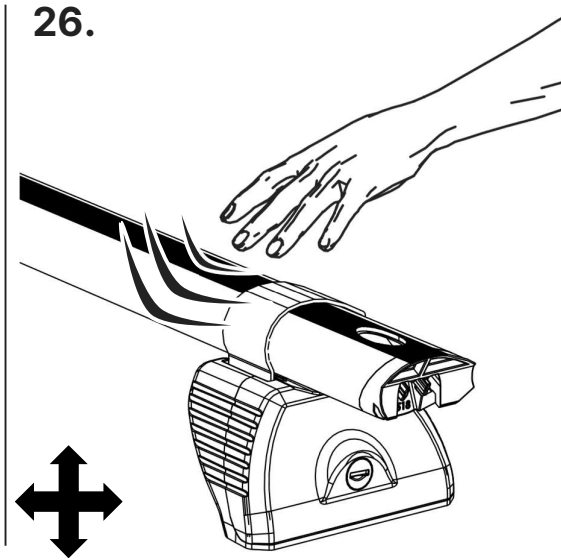
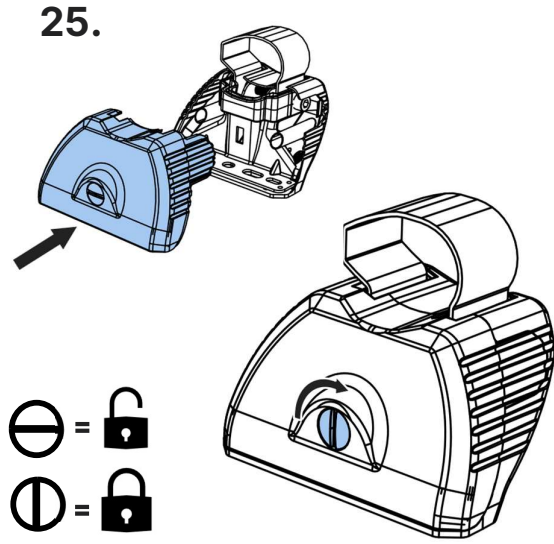

**K699- Kia, PV5, 2026- L2, H1, Twin Doors**

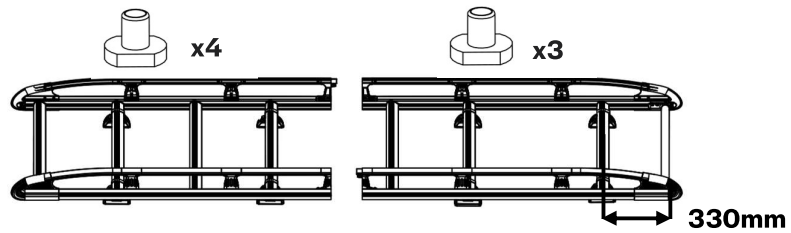
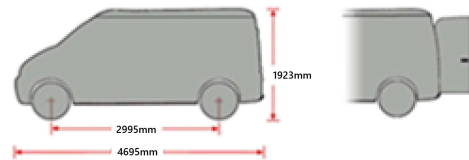
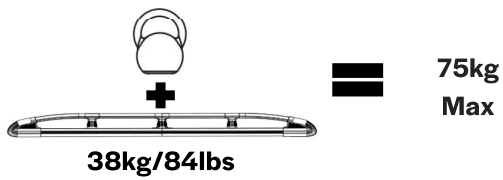

27.

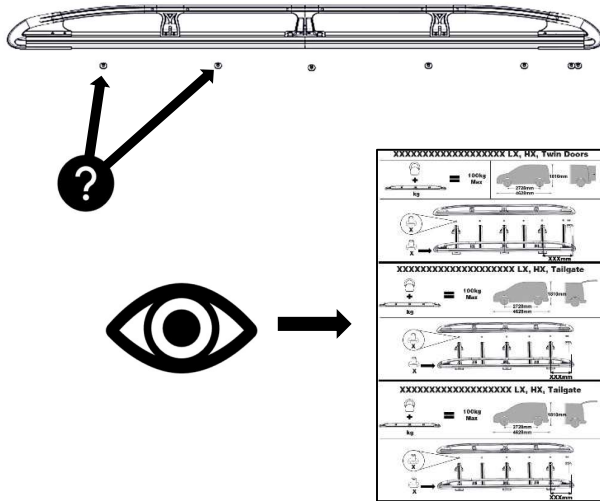

28.

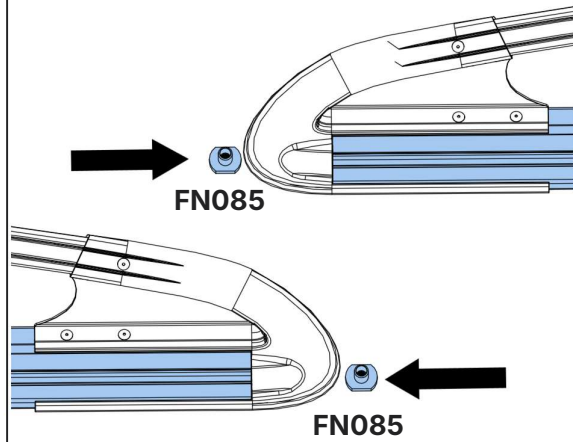

29.

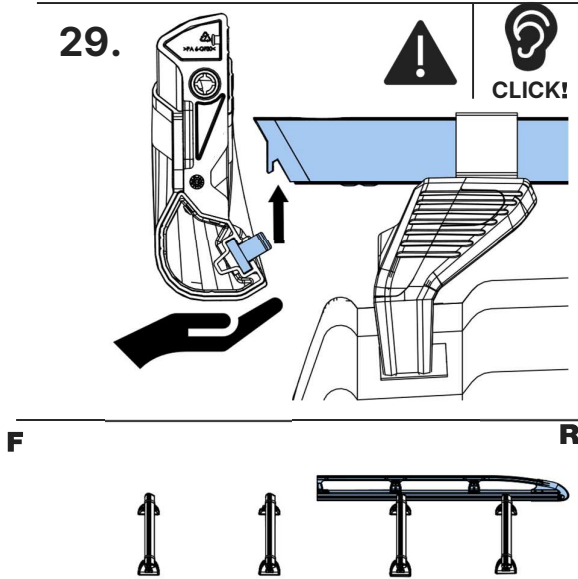

30.

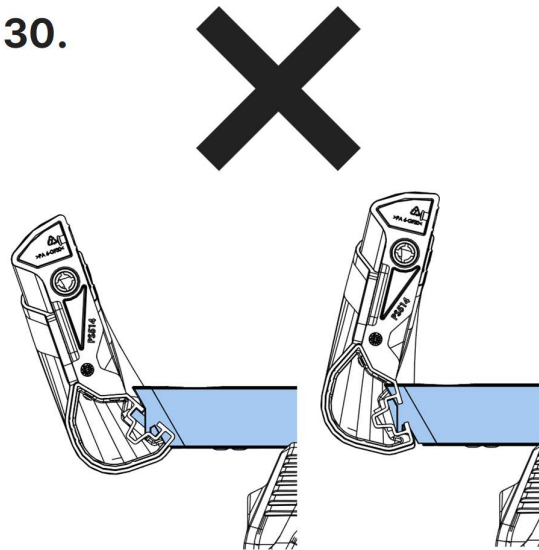

31.

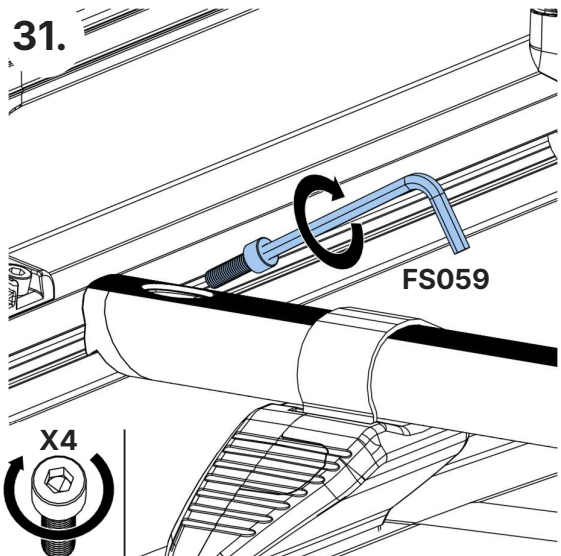

32.

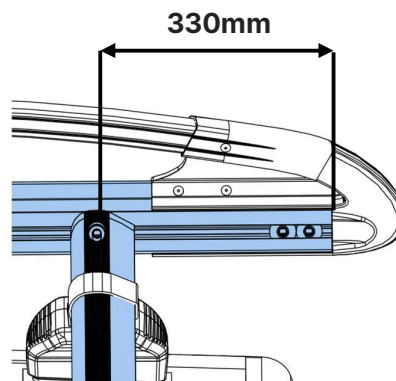

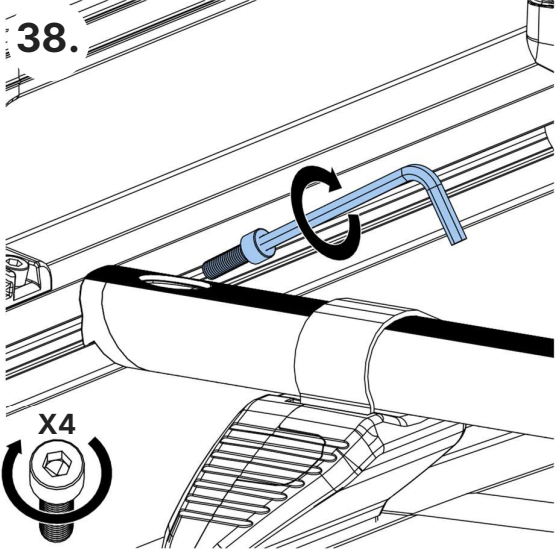
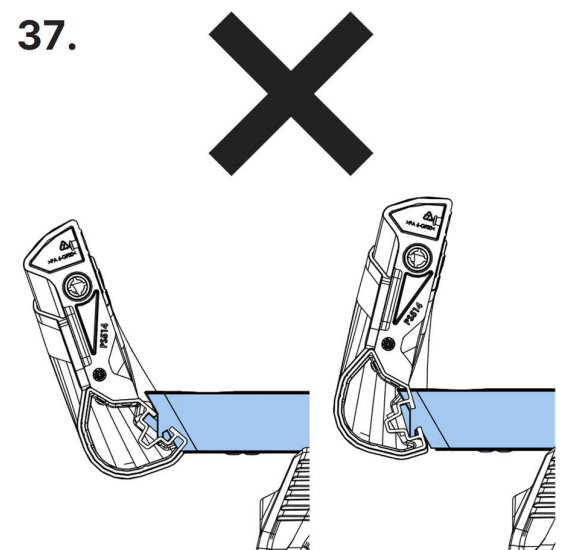
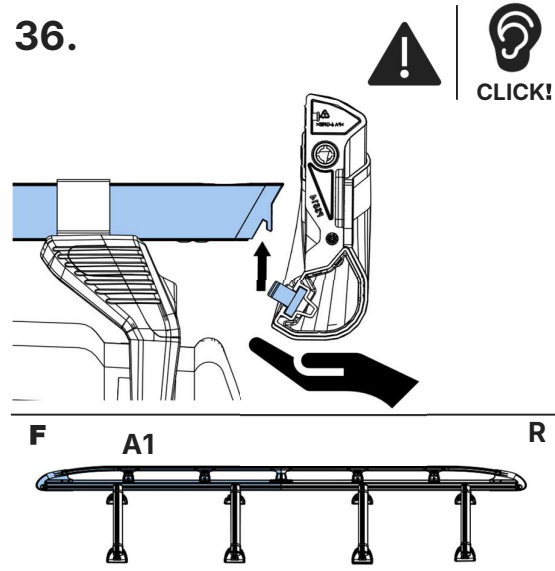
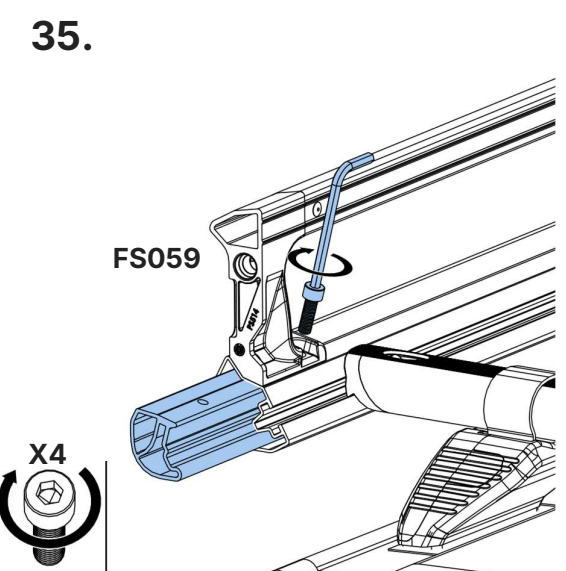
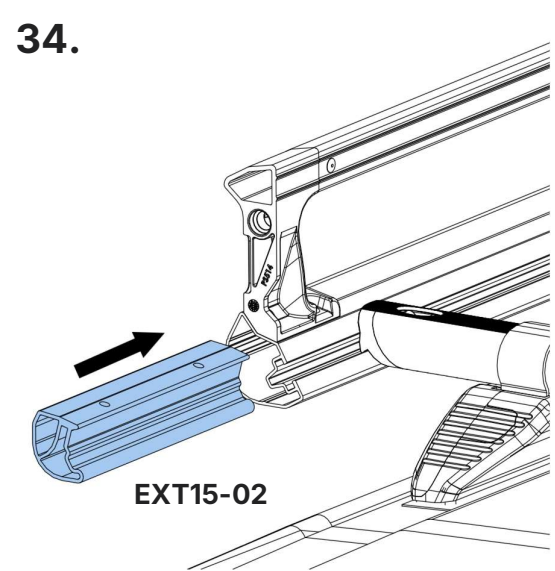
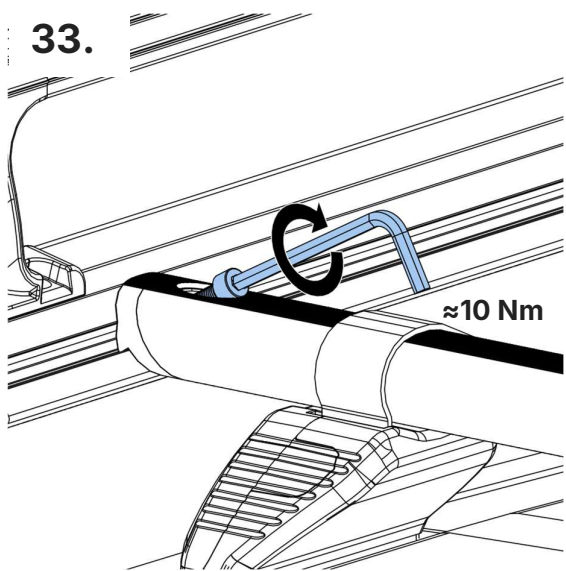

39.



CLICK!

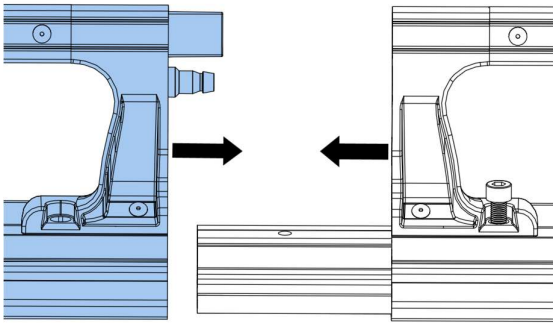

40.

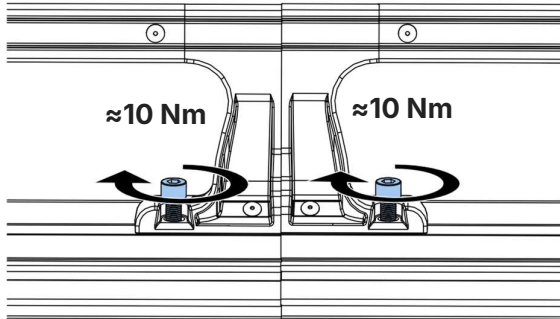

41.

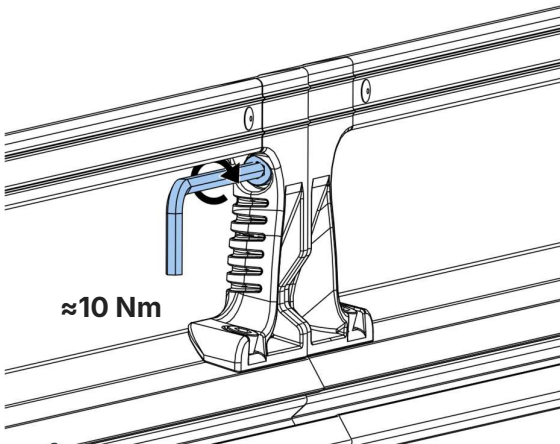

42.

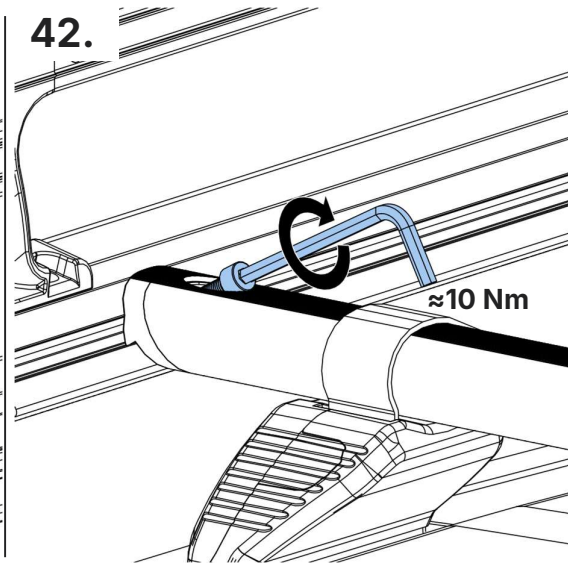

43.



→ 28-42

F

R

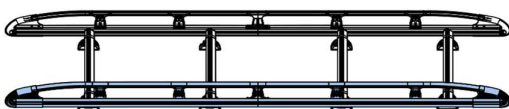

44.

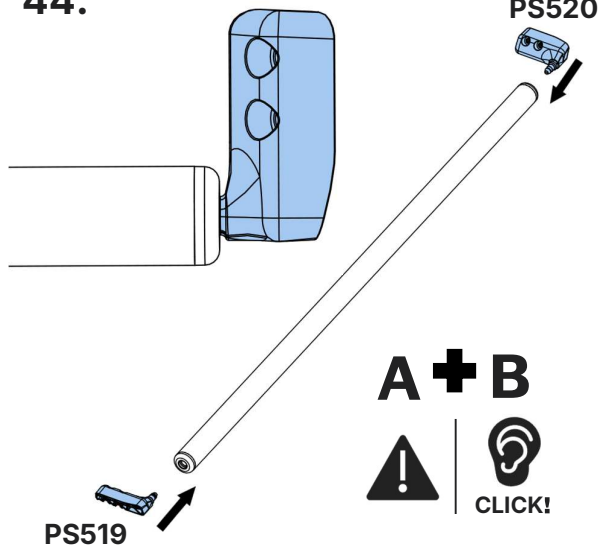

45.



CLICK!

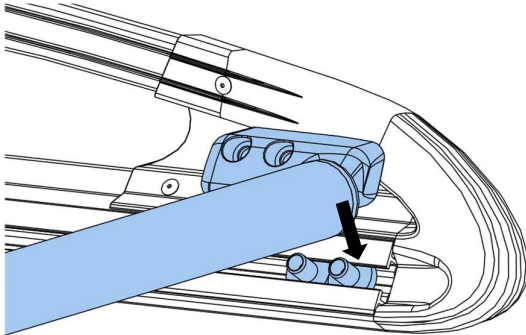

46.

30mm MAX

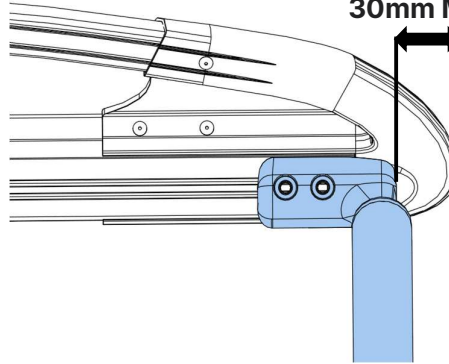

47.

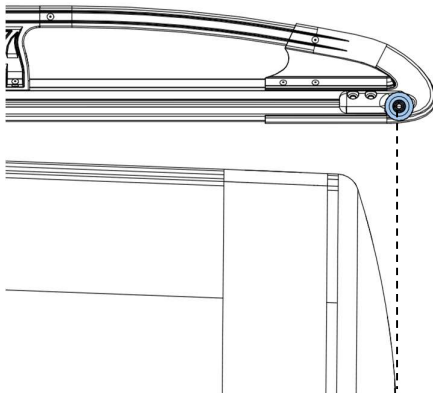

48.

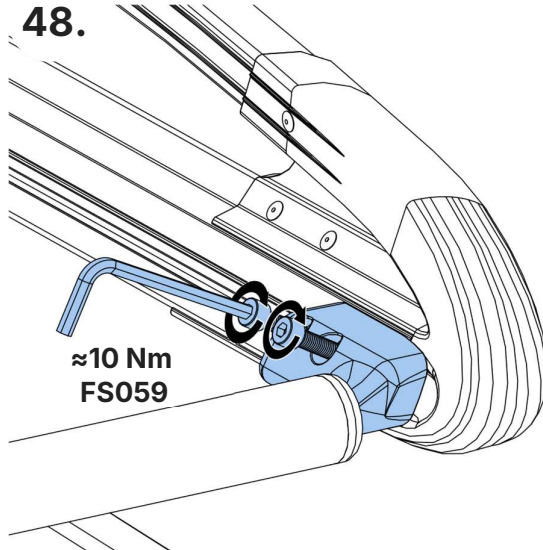

49.



CLICK!

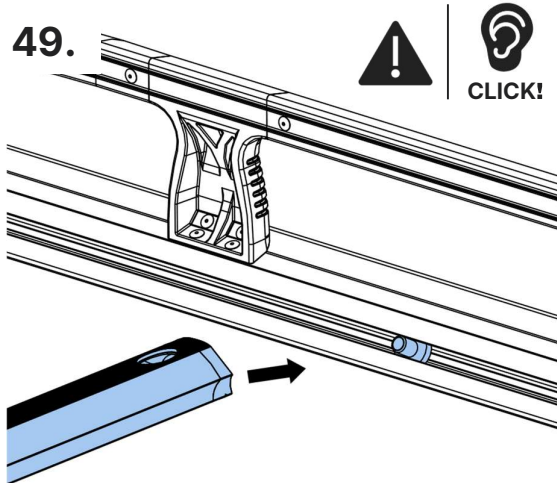

50.

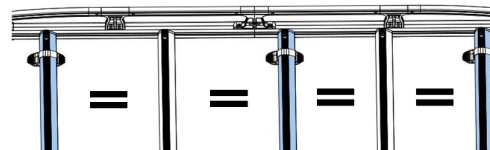
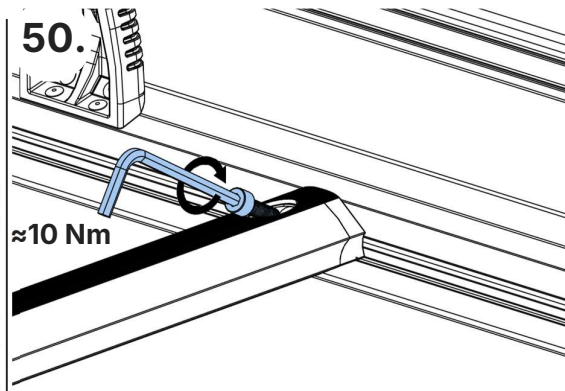

51.

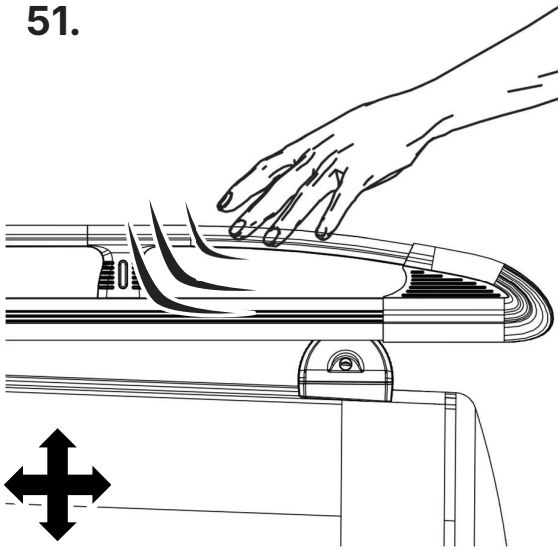

52.

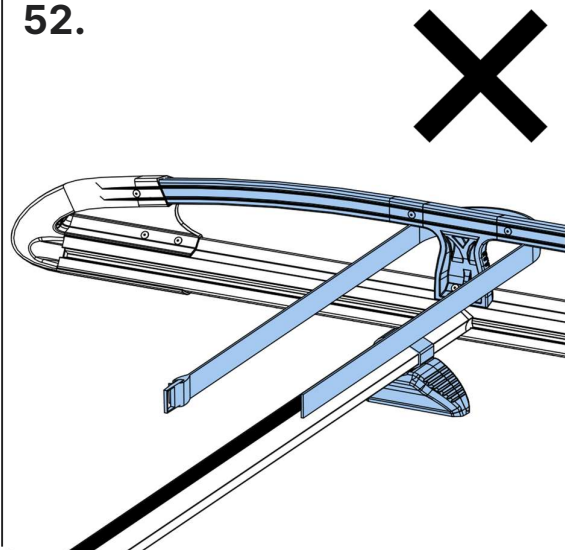

53.

